

# M5 FOR ZEISS

M5 Thread Styli	Order No.	Zeiss No.	wt	D mm	dk mm	d1 mm	L mm	ML mm
<b>Styli (Type S)</b> Ball: Ruby Shaft: Tungsten Carbide Ferrule: Steel	0.2-21.8-11 NTS	-	6g	11	0.2	0.15	21.8	1.5
	0.25-21.8-11 NTS	-	6g	11	0.25	0.2	21.8	2.5
	0.3-21.8-11 NTS	-	6g	11	0.3	0.2	21.8	2.5
	0.4-21.9-11 NTS	-	6g	11	0.4	0.3	21.9	2.5
	0.5-22.0-11 NTS	-	6g	11	0.5	0.3	22.0	2.5
	0.6-22.1-11 NTS	-	6g	11	0.6	0.4	22.1	4.5
	0.7-22.2-11 NTS	-	6g	11	0.7	0.4	22.2	4.5
	0.8-22.3-11 NTS	-	6g	11	0.8	0.6	22.3	4.5
	0.9-22.4-11 NTS	-	6g	11	0.9	0.6	22.4	4.5
	1.0-22.5-11 NTS	-	6g	11	1.0	0.8	22.5	4.5

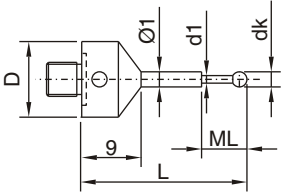

Styli with extended thread ( SL)	Order No.	Zeiss No.	wt	D mm	dk mm	d1 mm	L mm	ML mm
Ball: Ruby Shaft: Tungsten Carbide Ferrule: Steel	0.2-21.8-11 NTSL	-	6g	11	0.2	0.15	21.8	1.5
	0.25-21.8-11 NTSL	-	6g	11	0.25	0.2	21.8	2.5
	0.3-21.8-11 NTSL	600342-8250	6g	11	0.3	0.2	21.8	2.5
	0.4-21.9-11 NTSL	-	6g	11	0.4	0.3	21.9	2.5
	0.5-22.0-11 NTSL	600342-8251	6g	11	0.5	0.3	22.0	2.5
	0.6-22.1-11 NTSL	600342-8252	6g	11	0.6	0.4	22.1	4.5
	0.7-22.2-11 NTSL	-	6g	11	0.7	0.4	22.2	4.5
	0.8-22.3-11 NTSL	600342-8253	6g	11	0.8	0.6	22.3	4.5
	0.9-22.4-11 NTSL	-	6g	11	0.9	0.6	22.4	4.5
	1.0-22.5-11 NTSL	600342-8254	6g	11	1.0	0.8	22.5	4.5

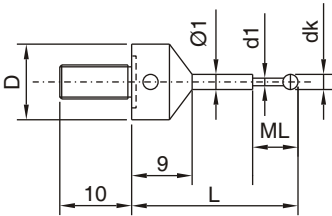

For use with **Disc styli with M5 thread** (Page 50).

Styli (Type S)	Order No.	Zeiss No.	wt	D mm	dk mm	d1 mm	L mm	ML mm
Ball: Ruby Shaft: Tungsten Carbide Ferrule: Steel	1.35-32.9-11 NTS	-	6g	11	1.35	1.0	32.9	23.9
	1.5-33-11 NTS	-	6g	11	1.5	1.0	33.0	24.0
	2.0-33.5-11 NTS	-	7g	11	2.0	1.5	33.5	24.5
	2.5-34-11 NTS	-	7g	11	2.5	1.5	34.0	25.0
	3.0-34.5-18 NTS	-	8g	18	3.0	2.0	34.5	16.5
	5.0-43.5-18 NTS	-	11g	18	5.0	3.5	43.5	25.5

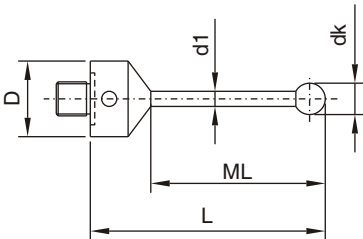

Styli with extended thread ( SL)	Order No.	Zeiss No.	wt	D mm	dk mm	d1 mm	L mm	ML mm
Ball: Ruby Shaft: Tungsten Carbide Ferrule: Steel	1.35-32.9-11 NTSL	600342-8200	6g	11	1.35	1.0	32.9	23.9
	1.5-33-11 NTSL	600342-8201	6g	11	1.5	1.0	33.0	24.0
	2.0-33.5-11 NTSL	600342-8202	7g	11	2.0	1.5	33.5	24.5
	2.5-34-11 NTSL	600342-8203	7g	11	2.5	1.5	34.0	25.0
	3.0-34.5-18 NTSL	600342-8221	8g	18	3.0	2.0	34.5	16.5
	5.0-43.5-18 NTSL	600342-8222	11g	18	5.0	3.5	43.5	25.5

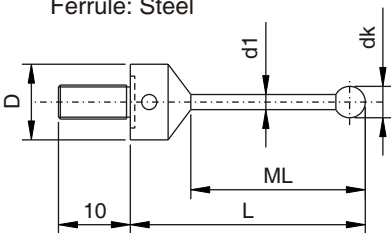

For use with **Disc styli with M5 thread** (Page 50).

# M5 FOR ZEISS

M5 Thread Styli	Order No.	Zeiss No.	wt	D mm	dk mm	d1 mm	L mm	ML mm
<b>Styli</b> Ball: Ruby Shaft: Tungsten Carbide Ferrule: Steel	0.2-32-11 NTB	-	7g	11	0.2	0.15	32.0	1.5
	0.25-32-11 NTB	-	7g	11	0.25	0.2	32.0	2.5
	0.3-32-11 NTB	-	7g	11	0.3	0.2	32.0	2.5
	0.4-32-11 NTB	-	7g	11	0.4	0.3	32.0	2.5
	0.5-32-11 NTB	-	7g	11	0.5	0.3	32.0	2.5
	0.6-32-11 NTB	-	7g	11	0.6	0.4	32.0	4.5
	0.7-32-11 NTB	-	7g	11	0.7	0.4	32.0	4.5
	0.8-32-11 NTB	602030-8060	7g	11	0.8	0.6	32.0	12.0
	0.9-32-11 NTB	-	7g	11	0.9	0.6	32.0	12.0
	1.0-32-11 NTB	602030-8061	7g	11	1.0	0.8	32.0	12.0
	1.35-32-11 NTB	602030-8062	7g	11	1.35	1.0	32.0	12.0
	1.35-44-11 NTB	602030-8063	7g	11	1.35	1.0	44.0	19.0
	1.5-32-11 NTB	602030-8064	7g	11	1.5	1.0	32.0	12.0
	1.5-44-11 NTB	602030-8065	7g	11	1.5	1.0	44.0	19.0
	2.0-32-11 NTB	602030-8066	7g	11	2.0	1.5	32.0	12.0
	2.0-44-11 NTB	602030-8067	8g	11	2.0	1.5	44.0	19.0
	2.0-58-11 NTB	602030-8068	8g	11	2.0	1.5	58.0	33.0
	2.5-32-11 NTB	602030-8069	7g	11	2.5	1.5	32.0	12.0
	2.5-44-11 NTB	602030-8070	8g	11	2.5	1.5	44.0	19.0
	2.5-58-11 NTB	602030-8071	8g	11	2.5	1.5	58.0	33.0

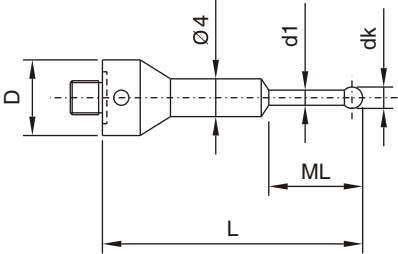

Styli	Order No.	Zeiss No.	wt	D mm	dk mm	d1 mm	L mm	ML mm
Ball: Ruby Shaft: Tungsten Carbide Ferrule: Steel	1.0-55-11 NTF	602030-9019	17g	11	1.0	0.8	55.0	4.0
	1.5-55-11 NTF	602030-9020	17g	11	1.5	1.0	55.0	5.0
	2.0-55-11 NTF	602030-9021	18g	11	2.0	1.5	55.0	5.0
	2.5-55-11 NTF	602030-9022	18g	11	2.5	1.5	55.0	5.0
	3.5-55-11 NTF	602030-9023	18g	11	3.5	2.0	55.0	10.0

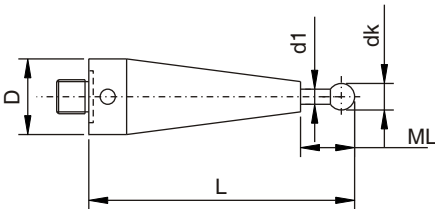

Styli with conus	Order No.	Zeiss No.	wt	D mm	dk mm	d1 mm	L mm	ML mm
Ball: Ruby Shaft: Tungsten Carbide Ferrule: Alu 7075	3.0-50-18 NTBK	600331-9096	13g	18	3.0	2.0	50.0	25.0
	3.0-75-18 NTBK	602030-9003	18g	18	3.0	2.0	75.0	35.0
	3.0-115-18 NTBK	600331-9098	31g	18	3.0	2.0	115.0	18.0
	5.0-75-18 NTBK	602030-9005	20g	18	5.0	3.5	75.0	35.0
	5.0-100-18 NTBK	602030-9007	26g	18	5.0	3.5	100.0	60.0
	8.0-80-18 NTBK	600331-9097	37g	18	8.0	6.0	80.0	55.0
	8.0-100-18 NTBK	600331-9099	45g	18	8.0	6.0	100.0	60.0
	8.0-115-18 NTBK	602030-9008	52g	18	8.0	6.0	115.0	75.0
	8.0-140-18 NTBK	602030-9009	65g	18	8.0	6.0	140.0	100.0

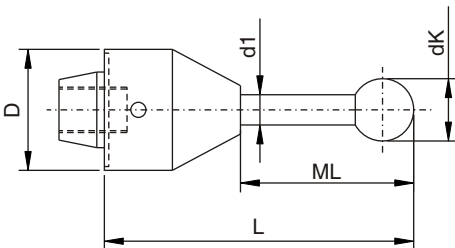

For use with static probe head with conical holding fixture.

# M5 FOR ZEISS

## M5 Thread Styli

### Styli (Type B)

Ball: Ruby  
Shaft: Tungsten Carbide  
Ferrule: Steel

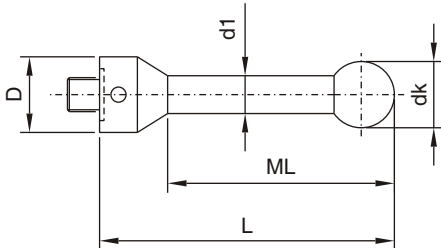

Order No.	Zeiss No.	wt	D mm	dk mm	d1 mm	L mm	ML mm
2.0-20-11 NTB	626115-020-020	6g	11	2.0	1.5	20.0	10.0
2.0-40-11 NTB	626115-0204-040	6g	11	2.0	1.5	40.0	30.0
2.5-20-11 NTB	626115-0250-020	6g	11	2.5	1.5	20.0	10.0
3.0-25-11 NTB	602030-9010	6g	11	3.0	2.0	25.0	15.0
3.0-33.5-11 NTB	600342-8020	6g	11	3.0	2.0	33.5	23.5
3.0-40-11 NTB	626115-0301-040	7g	11	3.0	2.0	40.0	30.0
3.0-50-11 NTB	602030-9011	7g	11	3.0	2.0	50.0	40.0
3.0-58-11 NTB	600342-8021	8g	11	3.0	2.0	58.0	48.0
4.0-33.5-11 NTB	600342-8025	7g	11	4.0	2.0	33.5	23.5
4.0-40-11 NTB	000000-1005-246	7g	11	4.0	2.0	40.0	30.0
4.0-50-11 NTB	626115-0402-050	8g	11	4.0	2.0	50.0	40.0
4.0-64-11 NTB	602030-9012	8g	11	4.0	2.0	64.0	54.0
5.0-40-11 NTB	626115-0500-040	11g	11	5.0	3.5	40.0	30.0
5.0-50-11 NTB	602030-9013	11g	11	5.0	3.5	50.0	40.0
5.0-53-11 NTB	600342-8022	12g	11	5.0	3.5	53.0	43.0
5.0-75-11 NTB	602030-9015	15g	11	5.0	3.5	75.0	65.0
5.0-80-11 NTB	626115-0502-080	16g	11	5.0	3.5	80.0	70.0
5.0-100-11 NTB		19g	11	5.0	3.5	100.0	90.0
6.0-54-11 NTB	600342-8026	12g	11	6.0	3.5	54.0	44.0
6.0-68-11 NTB	626115-0600-068	15g	11	6.0	3.5	68.0	58.0
7.0-55-11 NTB	600342-8027	13g	11	7.0	3.5	55.0	45.0
8.0-63.5-11 NTB	600342-8023	26g	11	8.0	6.0	63.5	50.5
8.0-74-11 NTB	602030-9014	32g	11	8.0	6.0	74.0	61.0
8.0-75-11 NTB	602030-9016	32g	11	8.0	6.0	75.0	62.0
8.0-100-11 NTB	602030-9017	42g	11	8.0	6.0	100.0	87.0
8.0-114.5-11 NTB	600342-8024	46g	11	8.0	6.0	114.5	101.5
8.0-150-11 NTB		62g	11	8.0	6.0	150.0	130.0
8.0-200-11 NTB		82g	11	8.0	6.0	200.0	180.0
9.0-64.5-11 NTB	600342-8028	27g	11	9.0	6.0	64.5	51.5
10.0-65.5-11 NTB	600342-8029	27g	11	10.0	6.0	65.5	52.5
10.0-118-11 NTB	602030-9018	49g	11	10.0	6.0	118.0	105.0
8.0-63.5-18 NTB	600342-8123	42g	18	8.0	6.0	63.5	41.5
8.0-114.5-18 NTB	600342-8124	63g	18	8.0	6.0	114.5	92.5
9.0-64.5-18 NTB	600342-8128	42g	18	9.0	6.0	64.5	42.5
10.0-65.5-18 NTB	600342-8129	43g	18	10.0	6.0	65.5	43.5

## Styli (Type K) Ceramic

Ball: Ruby  
Shaft: Ceramic  
Ferrule: Steel

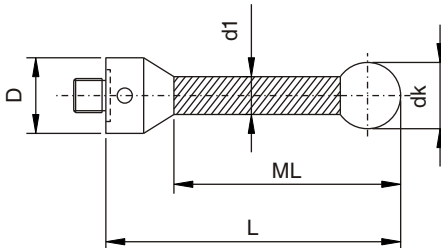

Order No.	Zeiss No.	wt	D mm	dk mm	d1 mm	L mm	ML mm
5.0-53-11 NTKE	600342-8013	7g	11	5.0	3.5	53.0	43.0
6.0-54-11 NTKE	600342-8016	7g	11	6.0	3.5	54.0	44.0
7.0-55-11 NTKE	600342-8017	8g	11	7.0	3.5	55.0	45.0
8.0-63.5-11 NTKE	600342-8014	12g	11	8.0	6.0	63.5	43.5
8.0-114.5-11 NTKE	600342-8015	18g	11	8.0	6.0	114.5	94.5
9.0-64.5-11 NTKE	600342-8018	13g	11	9.0	6.0	64.5	44.5
10.0-65.5-11 NTKE	600342-8019	13g	11	10.0	6.0	65.5	45.5
8.0-63.5-18 NTKE	600342-8114	32g	18	8.0	6.0	63.5	41.5
8.0-114.5-18 NTKE	600342-8115	38g	18	8.0	6.0	114.5	92.5
9.0-64.5-18 NTKE	600342-8118	32g	18	9.0	6.0	64.5	42.5
10.0-65.5-18 NTKE	600342-8119	33g	18	10.0	6.0	65.5	43.5

# M5 FOR ZEISS

## Styli (Type CA) Carbon fiber

Ball: Ruby  
Shaft: Carbon Fiber  
Ferrule: Steel

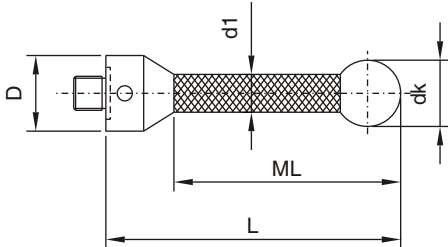

Order No.	Zeiss No.	wt	D mm	dk mm	d1 mm	L mm	ML mm
3.0-25-11 NTCA	-	4g	11	3.0	2.0	25.0	15.0
3.0-33.5-11 NTCA	-	4g	11	3.0	2.0	33.5	23.5
3.0-50-11 NTCA	-	4g	11	3.0	2.0	50.0	40.0
3.0-58-11 NTCA	-	4g	11	3.0	2.0	58.0	48.0
4.0-33.5-11 NTCA	-	5g	11	4.0	3.0	33.5	23.5
4.0-64-11 NTCA	-	5g	11	4.0	3.0	64.0	54.0
5.0-50-11 NTCA	-	6g	11	5.0	4.0	50.0	40.0
5.0-53-11 NTCA	-	6g	11	5.0	3.0	53.0	43.0
5.0-75-11 NTCA	-	6g	11	5.0	4.0	75.0	65.0
5.0-100-11 NTCA	-	6g	11	5.0	4.0	100.0	90.0
6.0-54-11 NTCA	-	6g	11	6.0	4.0	54.0	44.0
7.0-55-11 NTCA	-	7g	11	7.0	4.0	55.0	45.0
8.0-63.5-11 NTCA	-	8g	11	8.0	6.0	63.5	50.5
8.0-75-11 NTCA	-	8g	11	8.0	6.0	75.0	65.0
8.0-100-11 NTCA	-	9g	11	8.0	6.0	100.0	90.0
8.0-114.5-11 NTCA	-	11g	11	8.0	6.0	114.5	101.5
8.0-150-11 NTCA	-	12g	11	8.0	6.0	150.0	137.0
8.0-200-11 NTCA	-	13g	11	8.0	6.0	200.0	187.0
9.0-64.5-11 NTCA	-	9g	11	9.0	6.0	64.5	51.5
10.0-65.5-11 NTCA	-	9g	11	10.0	6.0	65.5	52.5
10.0-118-11 NTCA	-	11g	11	10.0	6.0	118.0	105.0
10.0-150-11 NTCA	-	12g	11	10.0	6.0	150.0	137.0
10.0-200-11 NTCA	-	13g	11	10.0	6.0	200.0	187.0
10.0-350-11 NTCA	-	27g	11	10.0	6.0	350.0	325.0
10.0-500-11 NTCA	-	34g	11	10.0	6.0	500.0	475.0
8.0-63.5-18 NTCA	-	29g	18	8.0	6.0	63.5	41.5
8.0-114.5-18 NTCA	-	31g	18	8.0	6.0	114.5	92.5
9.0-64.5-18 NTCA	-	29g	18	9.0	6.0	64.5	42.5
10.0-65.5-18 NTCA	-	30g	18	10.0	6.0	65.5	43.5

# M5 FOR ZEISS

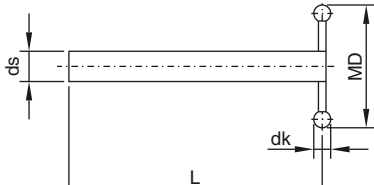
T-Styli (Type H)	Order No.	Zeiss No.	wt	dk mm	ds mm	MD mm	L mm
Ball: Ruby Shaft: Tungsten carbide 	1.0-50-2 NTTH	-	3g	1.0	2.0	10.0	50.0
	1.0-100-2 NTTH	-	5g	1.0	2.0	10.0	100.0
	2.0-50-2 NTTH	-	3g	2.0	2.0	20.0	50.0
	2.0-100-2 NTTH	-	5g	2.0	2.0	20.0	100.0
	1.0-50-3 NTTH	-	6g	1.0	3.0	10.0	50.0
	1.0-100-3 NTTH	-	10g	1.0	3.0	10.0	100.0
	2.0-50-3 NTTH	-	6g	2.0	3.0	20.0	50.0
	2.0-100-3 NTTH	-	10g	2.0	3.0	20.0	100.0

For use with **Adaptors for styli** (Page 53).

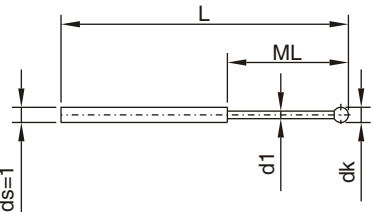
M5 Thread Styli	Order No.	Zeiss No.	wt	dk mm	d1 mm	L mm	ML mm
<b>Styli (Type F)</b> Ball: Ruby Shaft: Tungsten carbide 	0.2-15.2-1 NTF	-	0.2g	0.2	0.15	15.2	1.5
	0.25-15.3-1 NTF	-	0.2g	0.25	0.2	15.3	2.5
	0.3-15.3-1 NTF	600341-8450	0.2g	0.3	0.2	15.3	2.5
	0.4-15.4-1 NTF	-	0.2g	0.4	0.3	15.4	2.5
	0.5-15.5-1 NTF	600341-8451	0.2g	0.5	0.3	15.5	2.5
	0.6-15.6-1 NTF	600341-8452	0.3g	0.6	0.4	15.6	4.5
	0.7-15.7-1 NTF	-	0.3g	0.7	0.4	15.7	4.5
	0.8-15.8-1 NTF	600341-8453	0.3g	0.8	0.6	15.8	4.5
	0.9-15.9-1 NTF	-	0.3g	0.9	0.6	15.9	4.5
	1.0-16-1 NTF	600341-8454	0.4g	1.0	0.8	16.0	4.5

For use with **Adaptors for styli** (Page 53).

# M5 FOR ZEISS

## Styli (Type N)

Ball: Ruby  
Shaft: Tungsten carbide



Order No.	Zeiss No.	wt	dk mm	ds mm	L mm
1.35-26.4-1 NTN	600341-8500	0.3g	1.35	1.0	26.4
1.5-26.5-1 NTN	600341-8501	0.3g	1.5	1.0	26.5
2.0-26-1 NTN	-	0.3g	2.0	1.0	26.0
2.0-27-1.5 NTN	600341-8502	0.6g	2.0	1.5	27.0
2.0-45-1 NTN	-	0.5g	2.0	1.0	45.0
2.0-61-1 NTN	-	0.7g	2.0	1.0	61.0
2.0-81-1 NTN	-	1.0g	2.0	1.0	81.0
2.0-101-1 NTN	-	1.3g	2.0	1.0	101.0
2.5-27.5-1.5 NTN	600341-8503	0.6g	2.5	1.5	27.5
3.0-26.5-1.5 NTN	-	0.7g	3.0	1.5	26.5
3.0-38-2 NTN	600341-8510	2.0g	3.0	2.0	38.0
3.0-45-1.5 NTN	-	1.0g	3.0	1.5	45.0
3.0-61.5-1.5 NTN	-	1.6g	3.0	1.5	61.5
3.0-81.5-1.5 NTN	-	2.2g	3.0	1.5	81.5
3.0-101.5-1.5 NTN	-	2.8g	3.0	1.5	101.5
4.0-27-2 NTN	-	1.3g	4.0	2.0	27.0
4.0-45-2 NTN	-	2.1g	4.0	2.0	45.0
4.0-62-2 NTN	-	2.9g	4.0	2.0	62.0
4.0-82-2 NTN	-	3.9g	4.0	2.0	82.0
4.0-102-2 NTN	-	4.9g	4.0	2.0	102.0
5.0-27.5-2 NTN	-	1.4g	5.0	2.0	27.5
5.0-42.5-2 NTN	-	2.3g	5.0	2.0	45.0
5.0-45-3 NTN	600341-8511	6.0g	5.0	3.0	45.0
5.0-62.5-2 NTN	-	3.1g	5.0	2.0	62.5
5.0-82.5-2 NTN	-	4.0g	5.0	2.0	82.5
5.0-102.5-2 NTN	-	5.0g	5.0	2.0	102.5
6.0-28-2 NTN	-	1.6g	6.0	2.0	28.0
6.0-43-2 NTN	-	2.2g	6.0	2.0	43.0
6.0-63-2 NTN	-	3.2g	6.0	2.0	63.0
6.0-73-3 NTN	-	7.5g	6.0	3.0	73.0
6.0-83-2 NTN	-	4.2g	6.0	2.0	83.0
6.0-103-2 NTN	-	4.9g	6.0	2.0	83.0
6.0-103-3 NTN	-	10.5g	6.0	3.0	103.0
8.0-29-2 NTN	-	2.0g	8.0	2.0	29.0
8.0-44-3 NTN	-	6.5g	8.0	3.0	44.0
8.0-64-2 NTN	-	3.6g	8.0	2.0	64.0
8.0-73-3 NTN	-	7.5g	8.0	3.0	73.0
8.0-84-2 NTN	-	4.5g	8.0	2.0	84.0
8.0-103-3 NTN	-	10.5g	8.0	3.0	103.0

For use with **Adaptors for styli** (Page 53).

## M5 Thread Styli

### Styli

Shaft: Tungsten carbide

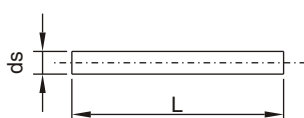

Order No.	Zeiss No.	wt	ds mm	L mm
1.0-30.0 NTH	-	1g	1.0	30.0
1.0-75.0 NTH	-	1g	1.0	75.0
1.5-30.0 NTH	-	1g	1.5	30.0
1.5-75.0 NTH	-	2g	1.5	75.0
2.0-30.0 NTH	-	2g	2.0	30.0
2.0-75.0 NTH	-	4g	2.0	75.0
3.0-30.0 NTH	-	4g	3.0	30.0
3.0-75.0 NTH	-	7g	3.0	75.0

All the above for use with **Adaptors for styli** (Page 53).

INDO SERVICES

TEL : +91 80 23406723, +91 80 23377556, MOBILE : +91 94482 89260, +91 94482 89262, E-mail : info@indoservices.net

# M5 FOR ZEISS

## Cylinder styli (Type A)

Cylinder: Ruby  
Ferrule: Steel

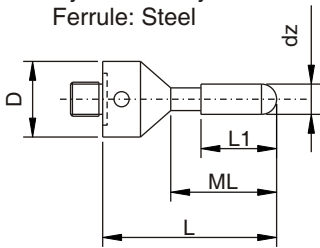

Order No.	Zeiss No.	wt	D mm	dz mm	L mm	ML mm	L1 mm
2.0-25-11 NZRA	-	6g	11	2.0	25.0	14.0	5.0
3.0-25-11 NZRA	-	6g	11	3.0	25.0	14.0	10.0
4.0-30-11 NZRA	-	7g	11	4.0	30.0	21.0	10.0

## Pointed styli

Point: Tungsten carbide  
Ferrule: Steel

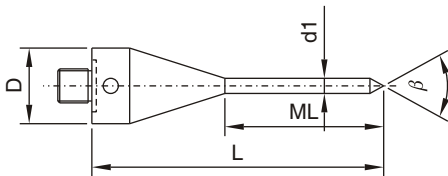

Order No.	Zeiss No.	wt	D mm	d1 mm	L mm	ML mm	$\beta$
30-61-11 NTS	600342-8051	12g	11	3.5	61.0	39.0	30°

## Ball disc styli

Disc: Polished ceramic  
Shaft: Alu 7075

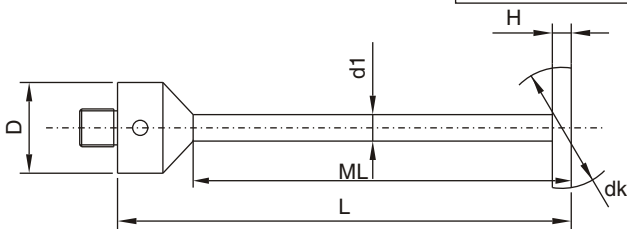

Order No.	Zeiss No.	wt	D mm	dk mm	H mm	L mm	ML mm	d1 mm
5.0-45-11 NKSK	-	7g	11	5.0	0.5	45.0	35.0	2.0
10.0-55-11 NKSK	-	11g	11	10.0	0.8	55.0	45.0	3.0
14.0-55-11 NKSK	-	11g	11	14.0	1.0	55.0	45.0	3.0

## Ball disc styli

Disc: Polished ceramic  
Shaft: Alu 7075

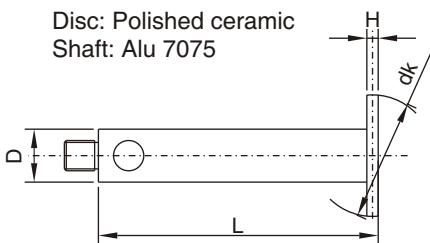

Order No.	Zeiss No.	wt	D mm	dk mm	H mm	L mm
15-40 NKSK	602030-8092	5g	7.0	15.0	1.0	40.0
20-60 NKSK	602030-8091	8g	7.0	20.0	1.0	60.0

# M5 FOR ZEISS

M5 Thread Styli	Order No.	Zeiss No.	wt	dk mm	H mm
<b>Disc styli with M5 thread</b> Disc: Hardened, polished steel	10-4 NTSG	602030-0003	2g	10.0	4.0
	15-4 NTSG	602030-0004	5g	15.0	4.0
	20-4 NTSG	602030-0005	11g	20.0	4.0
	30-4 NTSG	602030-0006	22g	30.0	4.0
	40-4 NTSG	602030-0007	33g	40.0	4.0
	50-5 NTSG	602030-0008	65g	50.0	5.0
	60-6 NTSG	602030-0009	115g	60.0	6.0

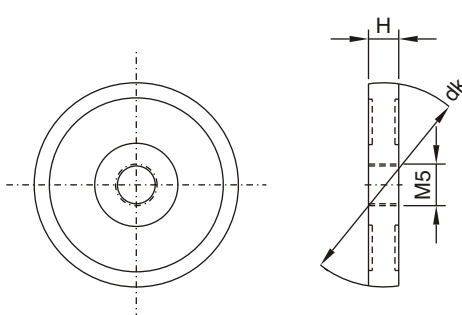

For use with **Styli with extended thread** (Page 43)  
**Oval head screw** (Page 59).

Disc styli with hole $\varnothing 8$ mm	Order No.	Zeiss No.	wt	dk mm	H mm
Disc: Hardened, polished steel	15-4 NTSA	602030-0010	4g	15.0	4.0
	20-2 NTSA	602030-0200	4g	20.0	2.0
	20-4 NTSA	602030-0011	8g	20.0	4.0
	30-4 NTSA	602030-0203	21g	30.0	4.0
	40-4 NTSA	602030-0204	32g	40.0	4.0
	50-5 NTSA	602030-0205	64g	50.0	5.0
	60-6 NTSA	602030-0206	112g	60.0	6.0

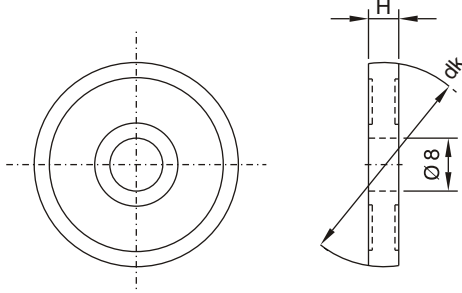

For use with **Screw for disc styli** (Page 59).

Hollow Ceramic ball styli	Order No.	Zeiss No.	wt	D	dk mm	L mm
Ball: Ceramic Shaft: Alu 7075	18.0-16-11 NHKE	-	8g	11	18.0	22.0
	24.0-19-11 NHKE	-	11g	11	24.0	27.0
	30.0-22-11 NHKE	-	14g	11	30.0	29.0

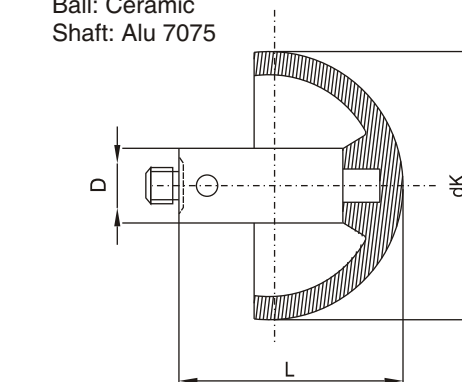

Ceramic ball styli	Order No.	Zeiss No.	wt	D mm	dk mm	L mm
Ball : Ceramic Body : Steel	12.0-28-11 NKE	-	12g	11	12.0	28.0
	14.0-28-11 NKE	-	14g	11	14.0	28.0
	15.0-28-11 NKE	-	15g	11	15.0	28.0
	16.0-28-11 NKE	-	16g	11	16.0	28.0
	18.0-28-11 NKE	-	20g	11	18.0	28.0
	20.0-33-11 NKE	-	24g	11	20.0	33.0
	24.0-37-11 NKE	-	36g	11	24.0	37.0
	30.0-43-11 NKE	-	62g	11	30.0	43.0

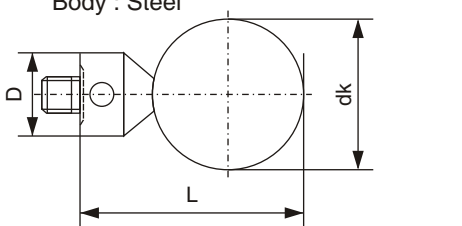

INDO SERVICES

TEL : +91 80 23406723, +91 80 23377556, MOBILE : +91 94482 89260, +91 94482 89262, E-mail : info@indoservices.net



# M5 FOR ZEISS

M5 Thread Styli	Order No.	Zeiss No.	wt	D mm	dk mm	d1 mm	MD mm	ML mm
<b>Styli for thread measuring</b> Ball: Ruby Shaft: Tungsten carbide Ferrule: Steel	0.5-40-11 NSTG	602030-9074	7g	11	0.5	0.4	3.5	1.9
	0.8-40-11 NSTG	602030-9073	7g	11	0.8	0.6	5.0	1.9
	1.35-40-11 NSTG	603030-9070	11g	11	1.35	1.05	9.0	2.0
	1.8-40-11 NSTG	602030-9072	12g	11	1.8	1.44	10.0	2.0
	2.3-40-11 NSTG	602030-9071	13g	11	2.3	1.84	12.0	2.5

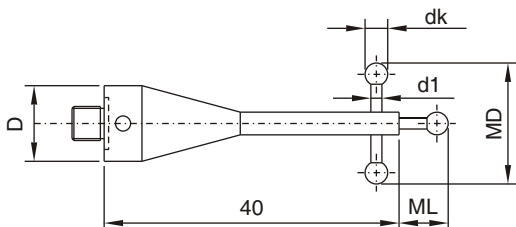

Star Styli	Order No.	Zeiss No.	wt	D mm	dk mm	d1 mm	MD mm
Ball: Ruby Shaft: Tungsten carbide Ferrule: Steel	5.0-80-19 NST	600331-8093	65.1g	19	5.0	3.5	80.0

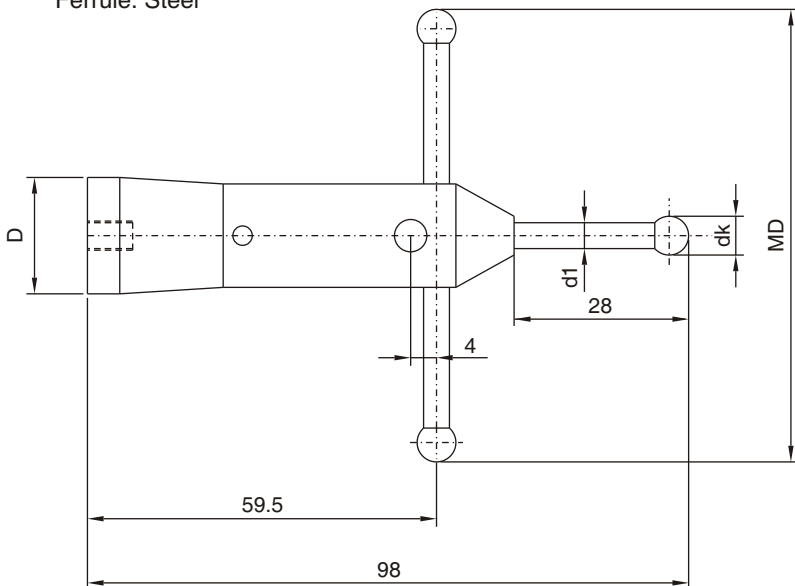

Cube stars	Order No.	Zeiss No.	wt	dk mm	d1 mm	MD mm	L mm
Ball: Ruby Cube: Alu 7075	1.0-45 NWST	602030-9024	10g	1.0	0.7	45.0	15.0
	1.5-45 NWST	602030-9025	10g	1.5	1.1	45.0	15.0
	2.0-45 NWST	602030-9026	11g	2.0	1.5	45.0	15.0
	2.5-45 NWST	602030-9027	11g	2.5	1.8	45.0	15.0
	3.5-45 NWST	602030-9028	12g	3.5	2.2	45.0	15.0

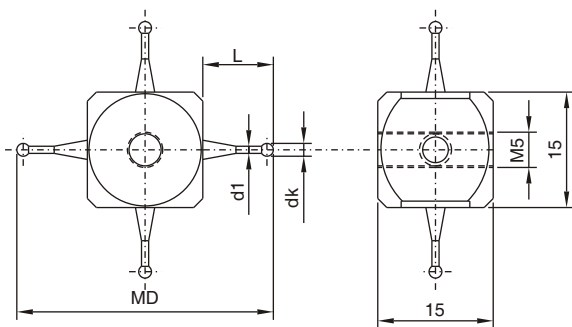

M3 thread styli can be replaced in case of damage

Replacement M3 thread styli:

1.0-15-3 NTC	-	1g	1.0	0.7		15.0
1.5-15-3 NTC	-	1g	1.5	1.1		15.0
2.0-15-3 NTC	-	1g	2.0	1.5		15.0
2.5-15-3 NTC	-	1g	2.5	1.8		15.0
3.5-15-3 NTC	-	1g	3.5	2.2		15.0

Replacement cube see Page 56.

INDO SERVICES

# M5 FOR ZEISS

M5 Thread Styli	Order No.	Zeiss No.	wt	D mm	ds mm
<b>Adaptor for Styli</b>	1.0-45-11 NHT	600341-8160	16g	11	1-1.5

Material: Steel

For use with **Styli (Type F)**, (**Type N**) with  $ds = 1 \dots 1.5$ mm (Pages 47 & 48).

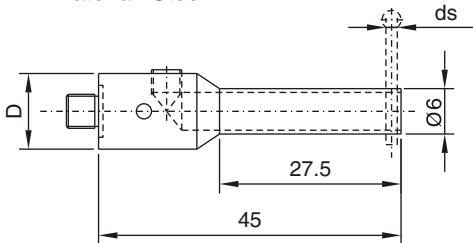

<b>Adaptor for styli swiveling</b>	Order No.	Zeiss No.	wt	D mm
Material: Steel	1.0-40-11 NHTS	600341-8180	15g	11

Material: Steel

For use with **Styli (Type S)**.

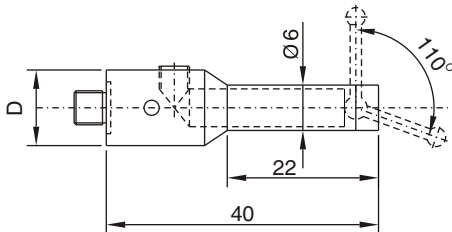

<b>Styli (Type S)</b>	Order No.	Zeiss No.	wt	dk mm	d1 mm	L mm	ML mm
Ball: Ruby Shaft: Tungsten carbide	1.0-17.5 NTES	600341-8183	1g	1.0	0.8	17.5	5.0

Use only with **Adaptor for styli swiveling**.

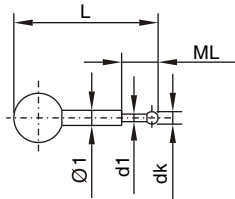

<b>Styli (Type S)</b>	Order No.	Zeiss No.	wt	dk mm	d1 mm	L mm
Ball: Ruby Shaft: Tungsten carbide	2.0-28.5 NTES	600341-8185	1g	2.0	1.5	28.5

Use only with **Adaptor for styli swiveling**.

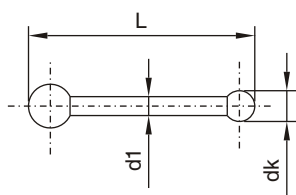

# M5 FOR ZEISS

## M5 Thread Styli

### Adaptors for styli (for max. 5 styli)

Material: Steel

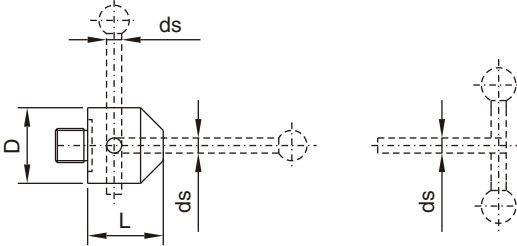

Order No.	Zeiss No.	wt	D mm	ds mm	L mm
1.0-10-11 NHT	600341-8367	6g	11	1.0	10.0
1.5-10-11 NHT	600341-8368	6g	11	1.5	10.0
2.0-10-11 NHT	-	6g	11	2.0	10.0

For use with **Styli (Type F)**, **T-Styli (Type H)**, (Page 47),  
**(Type N)** (Page 48).

## Adaptors for styli rotary (for max. 5 styli)

Material: Steel

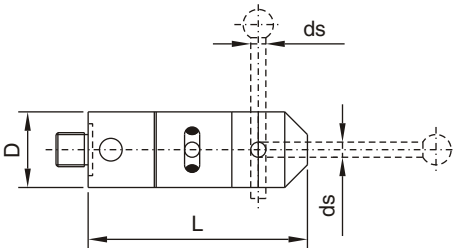

Order No.	Zeiss No.	wt	D mm	ds mm	L mm
1.0-32-11 NHTD	-	15g	11	1.0	32.0
1.5-32-11 NHTD	-	15g	11	1.5	32.0
2.0-32-11 NHTD	-	15g	11	2.0	32.0

For use with **Styli (Type F)**, **T-Styli (Type H)**, (Page 47),  
**(Type N)** (Page 48).

A built-in rotating adaptor allows stylus positioning

## Adaptors for styli

Material: Steel

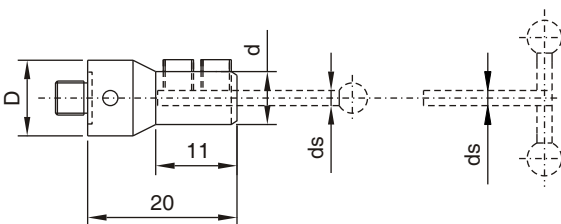

Order No.	Zeiss No.	wt	D mm	ds mm	d mm
1.0-20-11 NHT	-	9g	11	1.0	6.0
1.5-20-11 NHT	-	9g	11	1.5	7.0
2.0-20-11 NHT	-	9g	11	2.0	7.0
3.0-20-11 NHT	-	9g	11	3.0	8.0

For use with **Styli (Type F)**, **T-Styli (Type H)**, (Page 47),  
**(Type N)** (Page 48).

# M5 FOR ZEISS

M5 Thread Styli	Order No.	Zeiss No.	wt	D mm	L mm
<b>Extensions, Standard Aluminium</b> Solid Material (Steel thread)	25-11 NVAL	-	6g	11	25.0
	40-11 NVAL	600341-8261	10g	11	40.0
	50-11 NVAL	-	13g	11	50.0
	60-11 NVAL	600341-8262	15g	11	60.0
	80-11 NVAL	600341-8263	20g	11	80.0
	100-11 NVAL	600341-8264	25g	11	100.0
	120-11 NVAL	600341-8265	30g	11	120.0

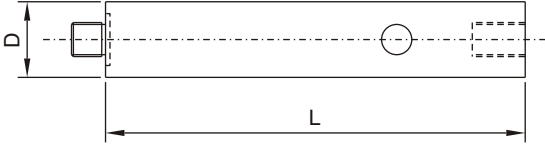

Extensions, Steel	Order No.	Zeiss No.	wt	D mm	L mm
Solid Material	10-11 NVST	600341-0250	6g	11	10.0
	15-11 NVST	600341-0251	10g	11	15.0
	20-11 NVST	600341-0252	13g	11	20.0
	25-11 NVST	-	17g	11	25.0
	40-11 NVST	600341-0254	28g	11	40.0
	60-11 NVST	600341-0256	42g	11	60.0
	80-11 NVST	600341-0258	56g	11	80.0
	100-11 NVST	600341-0260	70g	11	100.0

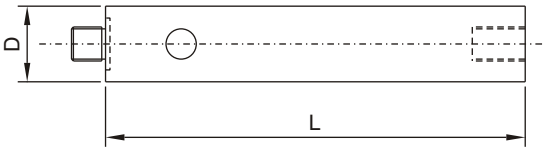

Extensions, Alu 7075	Order No.	Zeiss No.	wt	D mm	L mm
Solid Material	10-11 NVPE	-	2g	11	10.0
	15-11 NVPE	-	3g	11	15.0
	20-11 NVPE	-	5g	11	20.0
	25-11 NVPE	-	6g	11	25.0
	40-11 NVPE	-	10g	11	40.0
	50-11 NVPE	-	13g	11	50.0
	15-18 NVPE	-	10g	18	15.0
	25-18 NVPE	-	17g	18	25.0
	40-18 NVPE	-	28g	18	40.0
	50-18 NVPE	-	35g	18	50.0

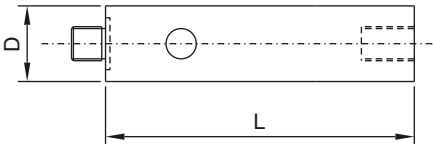

# M5 FOR ZEISS

## M5 Thread Styli

### Extensions, Light-weight Alu 7075

Tube material

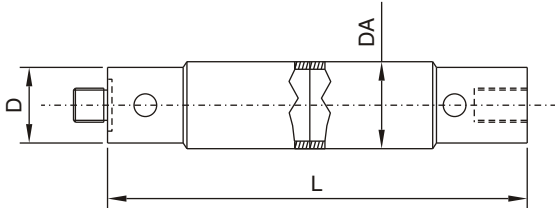

Order No.	Zeiss No.	wt	D mm	DA mm	L mm
60-11 NVPE	-	11g	11	12.0	60.0
75-11 NVPE	-	12g	11	12.0	75.0
80-11 NVPE	-	13g	11	12.0	80.0
90-11 NVPE	-	14g	11	12.0	90.0
100-11 NVPE	-	15g	11	12.0	100.0
120-11 NVPE	-	16g	11	12.0	120.0
150-11 NVPE	-	19g	11	12.0	150.0
200-11 NVPE	-	23g	11	12.0	200.0
60-18 NVPE	-	31g	18	20.0	60.0
75-18 NVPE	-	36g	18	20.0	75.0
80-18 NVPE	-	37g	18	20.0	80.0
90-18 NVPE	-	40g	18	20.0	90.0
100-18 NVPE	-	42g	18	20.0	100.0
120-18 NVPE	-	49g	18	20.0	120.0
150-18 NVPE	-	58g	18	20.0	150.0
200-18 NVPE	-	73g	18	20.0	200.0
250-18 NVPE	-	89g	18	20.0	250.0
300-18 NVPE	-	103g	18	20.0	300.0

## Extensions, Light-weight Carbon Fiber

Tube material

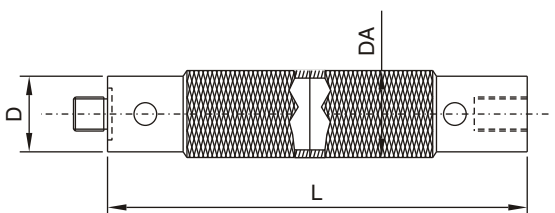

Order No.	Zeiss No.	wt	D mm	DA mm	L mm
40-11 NVCA	602030-0263	6.8g	11	12.0	40.0
50-11 NVCA	602030-0264	8.4g	11	12.0	50.0
60-11 NVCA	602030-0262	9g	11	12.0	60.0
75-11 NVCA	602030-0265	10g	11	12.0	75.0
80-11 NVCA	602030-0261	10g	11	12.0	80.0
90-11 NVCA	602030-0266	10g	11	12.0	90.0
100-11 NVCA	602030-0267	11g	11	12.0	100.0
120-11 NVCA	602030-0259	12g	11	12.0	120.0
150-11 NVCA	602030-0268	13g	11	12.0	150.0
160-11 NVCA	602030-0270	14g	11	12.0	160.0
200-11 NVCA	602030-0275	16g	11	12.0	200.0
210-11 NVCA	602030-0271	17g	11	12.0	210.0
250-11 NVCA	-	19g	11	12.0	250.0
300-11 NVCA	-	22g	11	12.0	300.0
400-11 NVCA	-	28g	11	12.0	400.0
50-18 NVCA	-	23g	18	20.0	50.0
60-18 NVCA	602030-0294	24g	18	20.0	60.0
80-18 NVCA	602030-0293	27g	18	20.0	80.0
100-18 NVCA	602030-0292	30g	18	20.0	100.0
120-18 NVCA	-	33g	18	20.0	120.0
150-18 NVCA	602030-0291	36g	18	20.0	150.0
200-18 NVCA	602030-0290	43g	18	20.0	200.0
250-18 NVCA	602030-0274	50g	18	20.0	250.0
300-18 NVCA	602030-0269	57g	18	20.0	300.0
400-18 NVCA	-	72g	18	20.0	400.0
500-18 NVCA	-	87g	18	20.0	500.0
600-18 NVCA	-	102g	18	20.0	600.0

# M5 FOR ZEISS

M5 Thread Styli	Order No.	Zeiss No.	wt	B mm
<b>Cubes M5</b>	15-15 NWA	602030-8363	8g	15
	20-20 NWA	602030-8362	20g	20

Material: Alu 7075

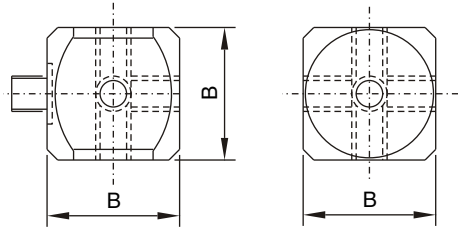

For use with **M5 thread components**.

For use with **Screw for cube** (Page 59).

<b>Cubes M5</b>	Order No.	Zeiss No.	wt	B mm
Material: Alu 7075	15-15 NWB	-	7g	15
	20-20 NWB	-	19g	20

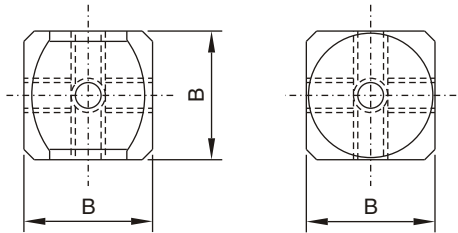

For use with **M5 thread components**.

For use with **Screw for cube** (Page 59).

<b>Cubes M5 / M3</b>	Order No.	Zeiss No.	wt	B mm
Material: Alu 7075	15-15 NWST	-	8g	15
	20-20 NWST	-	20g	20

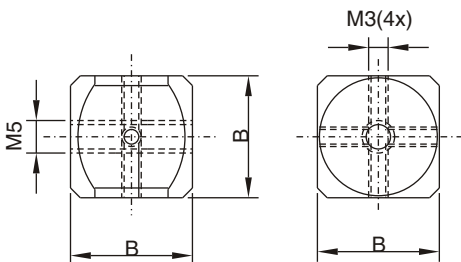

For use with **M3 thread styli** (e.g. cube stars, Page 51).

For use with **Screw for cube** (Page 59).

# M5 FOR ZEISS

M5 Thread Styli	Order No.	Zeiss No.	wt	B mm
<b>Double cubes M5</b>	20-20 NDW	600342-8103	40g	20

Material: Alu 7075

For use with **M5 thread components**.

For use with **Screw for cube** (Page 59).

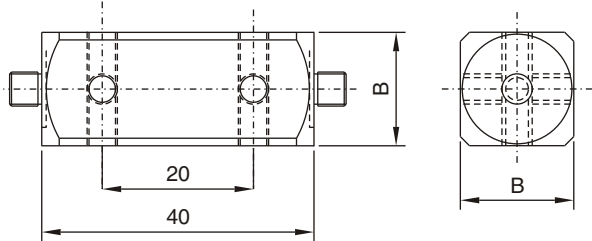

<b>Cube extensions M5</b>	Order No.	Zeiss No.	wt	B mm
Material: Alu 7075	20-20 NMW	-	144g	20

For use with **M5 thread components**.

For use with **Screw for cube** (Page 59).

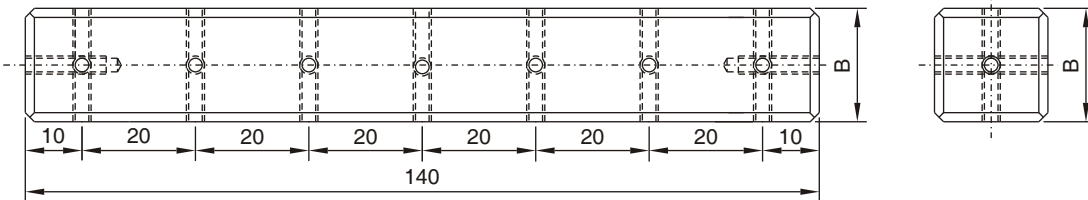

<b>Cube extensions M5</b>	Order No.	Zeiss No.	wt	B mm
Material: Alu 7075	20-20 NWV	602030-0019	55g	20

For use with **M5 thread components**.

For use with **Screw for cube** (Page 59).

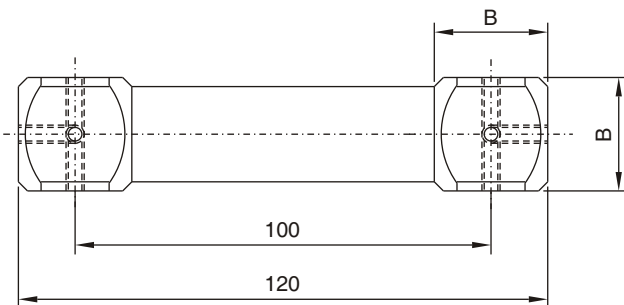

# M5 FOR ZEISS

M5 Thread Styli	Order No.	Zeiss No.	wt	D mm	L mm
<b>Knuckle joints</b>	30-11 NGA	600342-9002	7g	11	30.0
	36-18 NGA	600342-9003	24g	18	36.0

Material: Alu 7075

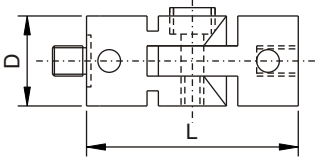

Knuckle joints rotary	Order No.	Zeiss No.	wt	D mm	L mm
Material: Alu 7075	43-11 NGD	-	13g	11	43.0
	55-18 NGD	-	38g	18	55.0

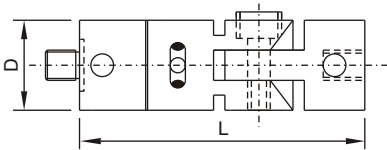

A built-in rotating adaptor allows stylus positioning.

Rotating adaptor	Order No.	Zeiss No.	wt	D mm	L mm
Material: Alu 7075	25-11 NDSP	602030-8358	9g	11	25.0
	25-18 NDSP	602030-8356	21g	18	25.0

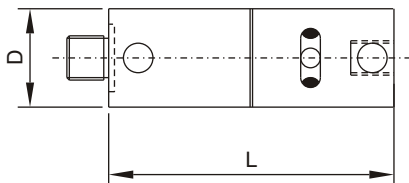

Rotating adaptor allows stylus positioning.



# M5 FOR ZEISS

M5 Thread Styli	Order No.	Zeiss No.	wt	D mm	L mm	ML mm
<b>Screw for cube</b>	5-20 NSWA	-	3g	11	31.0	20.0
	5-25 NSWA	-	3g	11	36.0	25.0

Material: Alu 7075

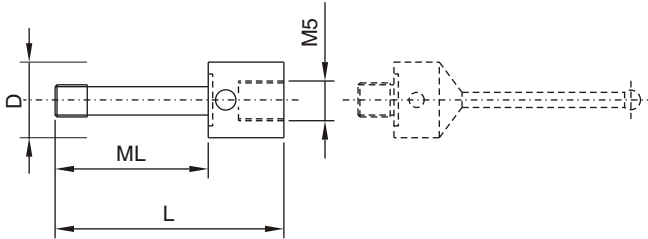

For cubes with **Cubes M5** (Page 56+57)

**M5 thread styli.**

Please Note:

**ML=20** fits to **Cube M5** with B=15

**ML=25** fits to **Cube M5** with B=20

The **Screw for cube** allows to position the cube.

<b>Screw for cube</b>	Order No.	Zeiss No.	wt	ML mm	
Material: Steel	5-20 NSWB	600341-0221	3g	20.0	
	5-25 NSWB	600341-0220	4g	25.0	

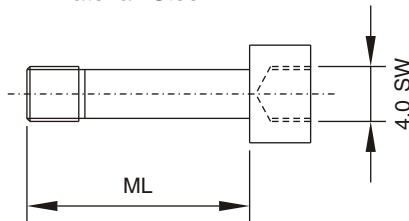

For cubes with **Cubes M5** (Page 56+57)

Please Note:

**ML=20** fits to **Cube M5** with B=15

**ML=25** fits to **Cube M5** with B=20

The **Screw for cube** allows to position the cube.

<b>Screw for disc styli</b>	Order No.	Zeiss No.	wt	L mm	ML mm	
Material: Steel	5-15.5 NST	600341-0212	7g	15.5	8.0	
	5-30 NST	600341-0211	9g	30.0	21.0	
	5-35 NST	600341-0210	9g	35.0	26.0	

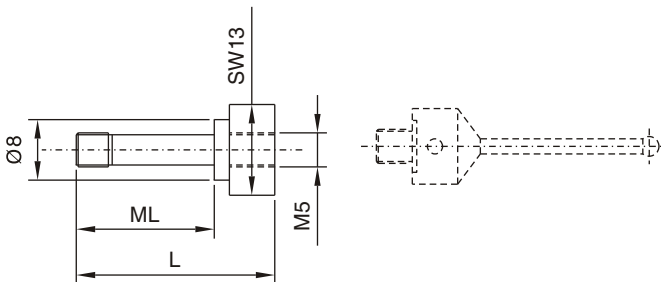

For use with **Disc styli with hole Ø 8 mm** (Page 50)

Together with **Cube M5** (Page 56+57).

Please Note:

**ML=8** fits to **Extension M5**

**ML=21** fits to **Cube M5** with B=15

**ML=26** fits to **Cube M5** with B=20

<b>Oval head screw</b>	Order No.	Zeiss No.	wt	ML mm	
Material: Steel	5-10 NSL	-	2g	10.0	
	5-12 NSL	-	2g	12.0	

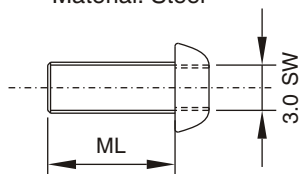

For use with **Disc styli with M5 thread** (Page 50).

# M5 TOOLS FOR ZEISS

Tools for M5 thread styli	Order No.	Zeiss No.	Description
<b>Pin key</b>	1.7 NWST	602030-0027	Ø 1.7 mm for rotating adaptors D=11
	2.9 NWST	602030-0222	Ø 2.9 mm for M5 thread components
	1.7-2.9 NWST	600341-8596	1X Ø 1.7mm, 1X Ø 2.9 mm

## 1.7 - 2.9 NWST

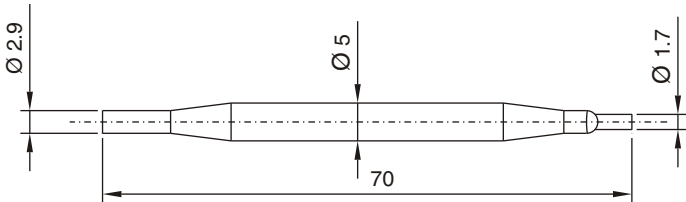

## 2.9 NWST

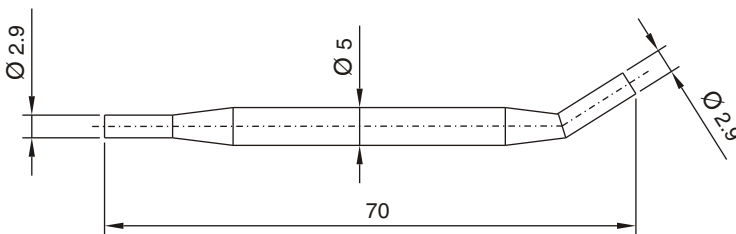

Hexagon key	Order No.	Zeiss No.	Description
	0.9 NWSK	-	SW 0.9mm for M2 screws
	1.5 NWSK	-	SW 1.5mm for M3 screws
	2.0 NWSK	-	SW 2.0mm for M4 screws
	2.5 NWSK	-	SW 2.5mm for M3 cylinder screws
	3.0 NWSK	-	SW 3.0mm for M5 oval head screws
	4.0 NWSK	-	SW 4.0mm for M5 cylinder screws

# M5 SETS FOR ZEISS

M5 thread styli	Order No.	Contents	
<b>M5 thread stylus set (Standard)</b>	30-11 NTBST	30 Parts	

Styli and accessories are available in stylus sets. This standard set is stocked with the most common styli and accessories needed to perform simple measurements successfully.

The empty spaces offer the possibility of enlarging your set at any time with the components needed for even the most specialized measurement needs.

Your stylus set is protected from dust and damage in a generously sized foam case with a cover.

Supplied Equipment:			Drawing
4 Pc	Stylus	3.0-33.5-11 NTB	Page 45
2 Pc	Stylus	3.0-58-11 NTB	Page 45
1 Pc	Stylus	5.0-53-11 NTB	Page 45
1 Pc	Stylus	8.0-63.5-11 NTB	Page 45
1 Pc	Stylus	8.0 - 114.5 - 11 NTKE	Page 45
1 Pc	Stylus	2.0-55-11 NTF	Page 44
1 Pc	Stylus	1.5-26.5-1 NTN	Page 48
1 Pc	Adaptor for styli	1.0-10-11 NHT	Page 53
1 Pc	Rotating adaptor	25-11 NDSP	Page 58
2 Pc	Cube	15-15 NWA	Page 56
2 Pc	Cube	15-15 NWB	Page 56
1 Pc	Knuckle joint	30-11 NGA	Page 58
2 Pc	Screw for cube	5-20 NSWA	Page 59
2 Pc	Screw for cube	5-20 NSWB	Page 59
2 Pc	Extension	40-11 NVPE	Page 54
2 Pc	Extension	60-11 NVPE	Page 55
1 Pc	Extension	100-11 NVPE	Page 55
2 Pc	Extension	120-11 NVPE	Page 55
1 Pc	Pin key set	1.7-2.9 NWST	Page 60

